

# CONTENTS

## B - Series contents

Introduction	
Features	
Technical characteristics	
Code numbering system, termination style	
contact arrangements	
Dimensional data and panel cutouts	

Page	Technical characteristics	7
2	Code numbering systems, termination style, contact arrangements	8
3	Dimensional data and panel cutouts	9
4	Micro coaxial contacts	10
4	Micro coaxial contact assembly	11
5	Contact types and tooling	12
5	Locking system and connector mounting plates	13

## MCS-R Series contents

Introduction	
Features	

6	<b>Accessories for B and MCS-R Series</b>	
	Hoods - top cable entry	14
	Hoods - side cable entry	15

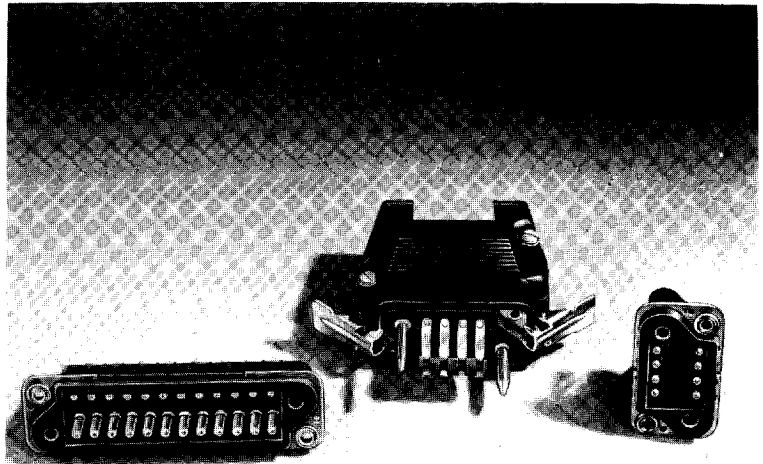

# B SERIES

## INTRODUCTION

These connectors are of robust design with fixed solder pot contacts of 15 A current rating, they are available in four contact arrangements. By their ruggedness, they are particularly suitable for rack and panel and cable to panel applications, ensuring complete safety for the following applications ; industries, transports, communications and power equipment and all specific civil and military electronic systems.



# FEATURES

Male and female connectors are made of a thermoset insulator moulded onto a stainless steel fixing plate.

**Four contact arrangements** are available, **8, 14, 24 and 32 contacts**.

The female box type connectors are fitted with round pin contacts. The male connectors are fitted with spring blade contacts and two stainless steel guide pins of different diameter providing polarization and mating before the contacts to ensure correct alignment.

The pin contacts are in silver plated brass, the spring blade contacts are in silver plated bronze, their cambered configuration and elasticity procure a self wiping condition at each mating, ensuring high reliability.

The B series connector is only available with solder pot termination for gauge 16 wires.

Standard female connectors are fitted with floating eyelets, which allow 0,75 mm radial float.

# TECHNICAL CHARACTERISTICS

## Materials

Insulator block	glass filled phenolic
Pin contacts (male)	brass - silver plated
spring blade contacts (female)	bronze silver plated
guide pins	stainless steel
fixing plate	stainless steel

## Electrical characteristics

Current rating by contact	15 A
Test voltage	
– between contacts	> 1500 V.r.m.s.
– between contacts and earth	> 2000 V.r.m.s.
Insulation resistance	> 5000 M $\Omega$
Contact resistance	< 10 M $\Omega$

## Environmental characteristics

Life	500 matings
Contact retention	> 50 N
Environmental rating	435
	(– 55° C + 125° C, 21 days)

# CODE NUMBERING SYSTEM

The table on the right shows how to order a part. For hoods and accessories refer to pages 14 and 15. When a female connector is ordered with the locking system, in place of the floating eyelets, brackets are fitted whilst the locking clips are always fitted on the hood.

The male connector is fitted with spring leaf contacts and the female box type connector with pin contacts.

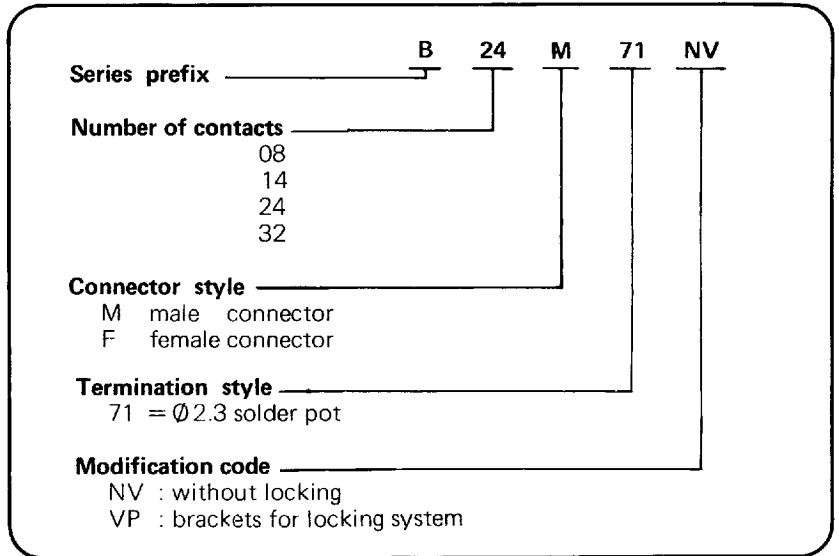

## TERMINATION STYLE

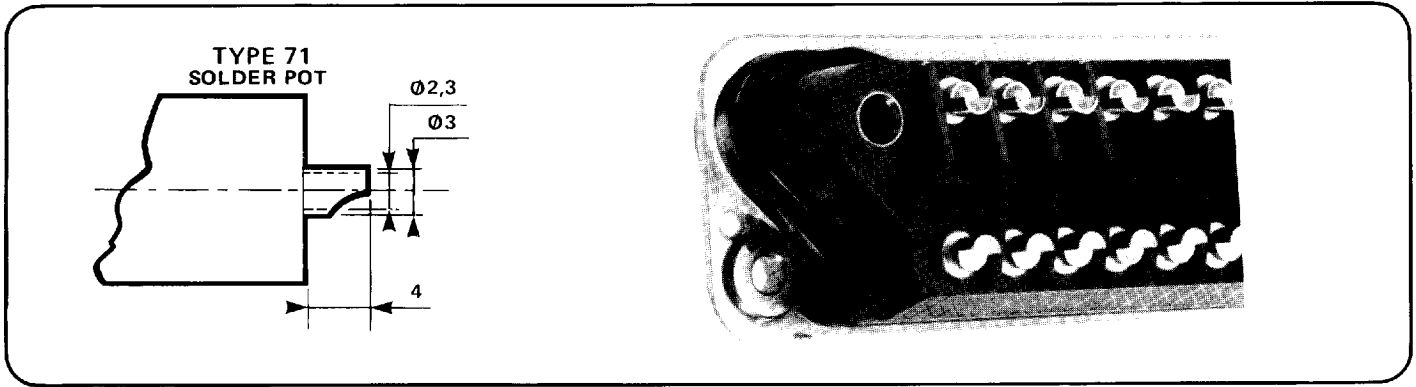

## CONTACT ARRANGEMENTS

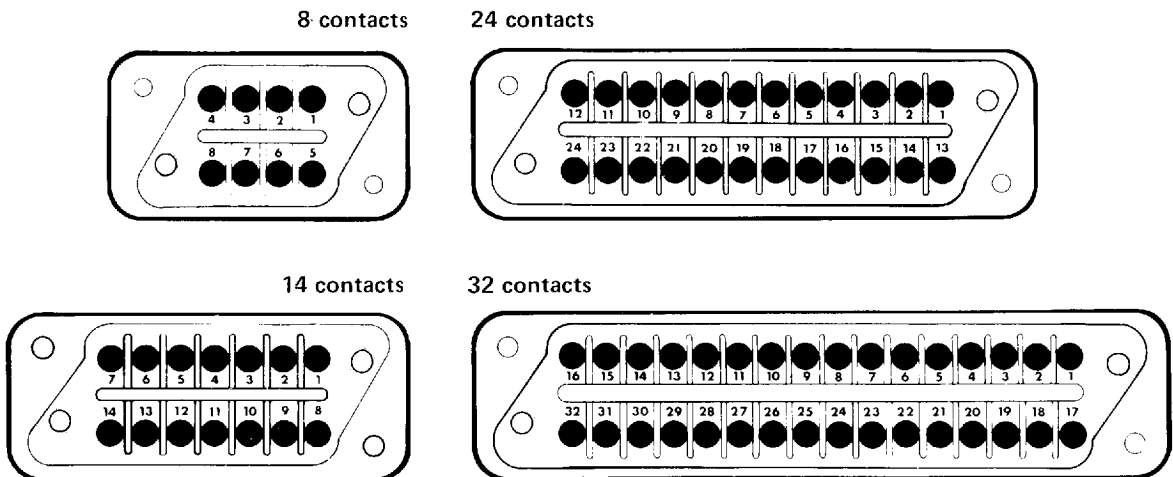

# DIMENSIONAL DATA

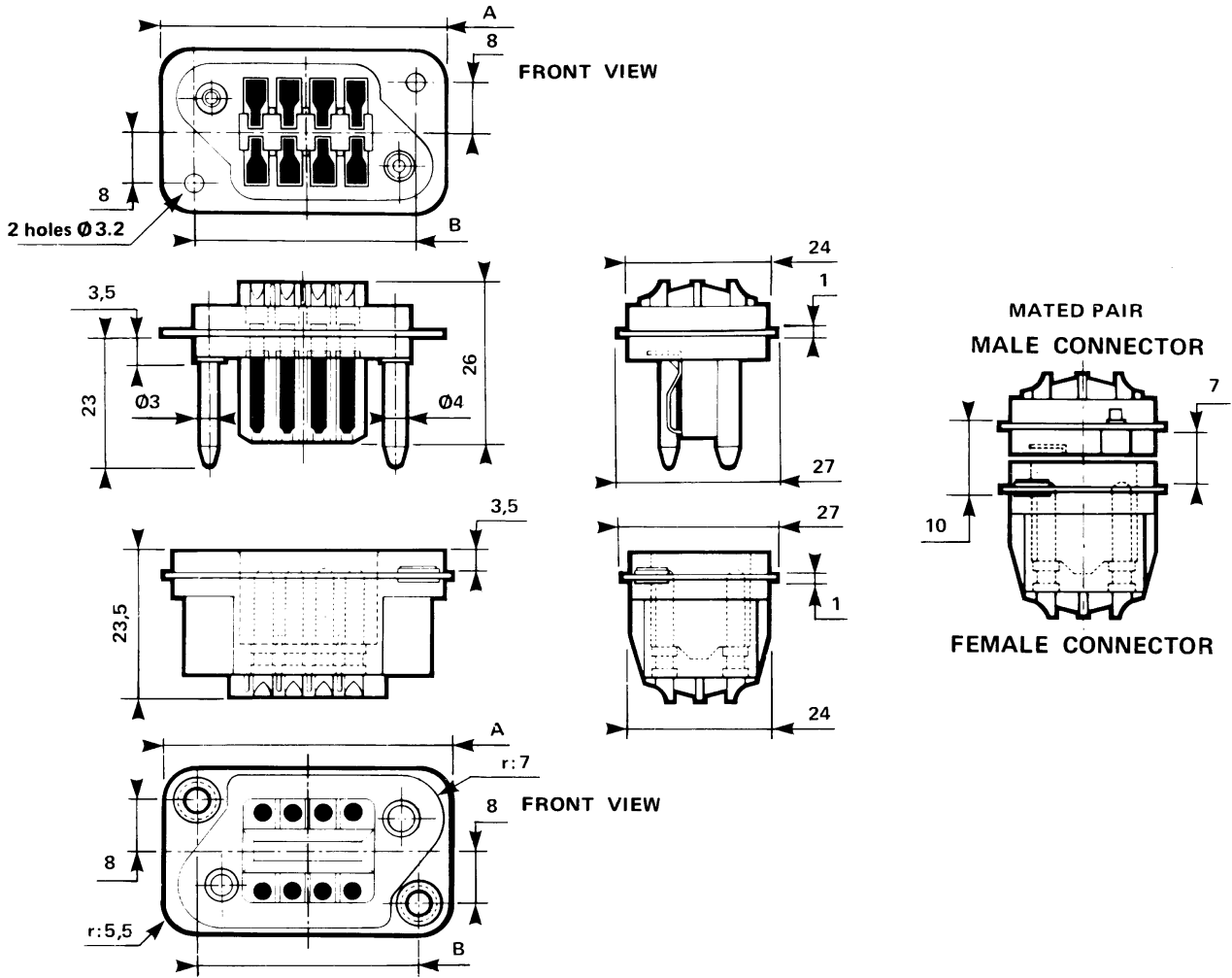

## PANEL CUT OUTS

FRONT VIEW

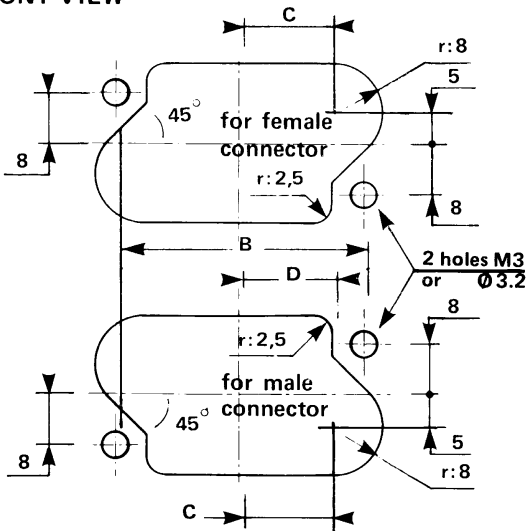

Number of contacts	Male and female connector dimensions			
	A	B	C	D
08	48,5	37,5	15,75	15,5
14	65	54	24	23,5
24	92,5	81,5	37,75	37,5
32	114,5	103,5	48,75	48,5

# MCSR SERIES

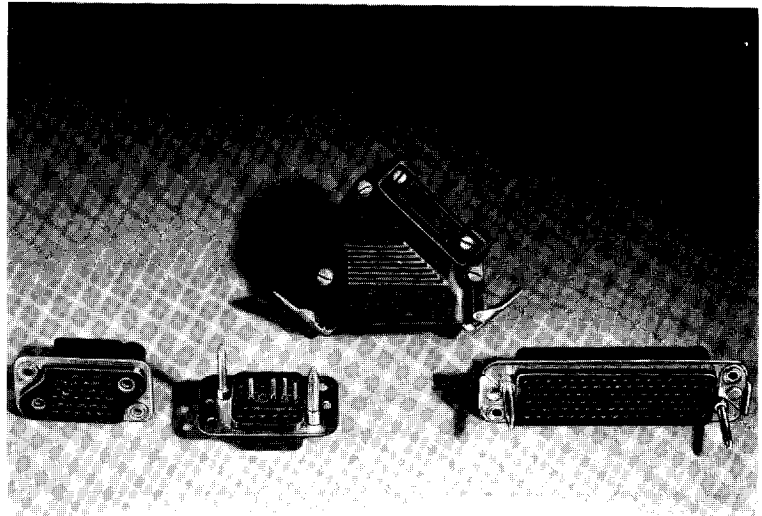

## INTRODUCTION

The MCS-R series connectors are of robust design and available in **four contacts layouts**, comprising respectively **28, 48, 83 and 113 wire contacts**, size gauge 16. The same number of micro coaxial contacts can be installed in place of the wire contacts.

A unique feature of the MCS-R connector is that it's interchangeable with the B series, but not intermateable ; the MCS-R series connectors are suitable for various applications in the following industrial fields : communications and automation systems, Navy, Aeronautics and Electronic equipments. The MCS-R connectors may be adapted with die cast aluminium hoods, with two types of cables entries, top or side.

# FEATURES

The MCS-R series, male and female connectors are made of a thermostat insulator moulded onto a stainless steel fixing plate. The male connector is fitted with two guide pins of different diameter, which provide polarization and mate before the contacts ensuring a perfect alignment and reliability. The male connector accepts male wire contacts or female micro coaxial contacts. The female connector accepts female wire contacts or male micro coaxial contacts and is fitted with floating eyelets which allow 0,75 mm radial float.

Three termination styles on the contacts are available, wire contacts with solder pot or crimp for wire size gauge 16 and micro coaxial contacts, crimp style.

# TECHNICAL CHARACTERISTICS

## Materials

Insulator block	glass filled phenolic
fixing plate	stainless steel
guide pins	stainless steel
Contacts	copper alloy - gold over nickel plated

## Electrical characteristics (Wire contacts)

Current rating by contact	13 A
Operation voltage	350 V.r.m.s at 50 Hz
Test voltage	1500 V.r.m.s. at 50 Hz
Insulation resistance	> 5000 M $\Omega$
Contact resistance	< 12 M $\Omega$

## (Micro coaxial contacts)

Impedance	50 $\Omega$
Operating frequency range	0 to 1 000 MHz
VSWR of pair of contacts	<1.4 from 0 to 1000 MHz
Insertion loss of a pair of contacts at 1000 MHz	: < 0,20 dB
Test voltage at sea level (mated pair)	600 V.r.m.s at 50 Hz
Insulation resistance	> 5000 M $\Omega$
Contact resistance by contact	< 12 m $\Omega$

## Environmental characteristics

Life	500 matings
Contact retention	> 50 N
Environmental rating	435
	( - 55° C + 125° C, 21 days)

# CODE NUMBERING SYSTEM

As for the series B connector, part ordering is explained by the table here in. For hoods and accessories refer to pages 14 and 15.

When ordering a connector with its locking system VP, brackets fitted on the female connector replace the eyelets, whilst the locking clips are always fitted on the hood. Series MCS-R contacts are removeable. Contacts shall be ordered separately following the termination style and quantities desired. Refer to pages 10 to 12 for the contact references.

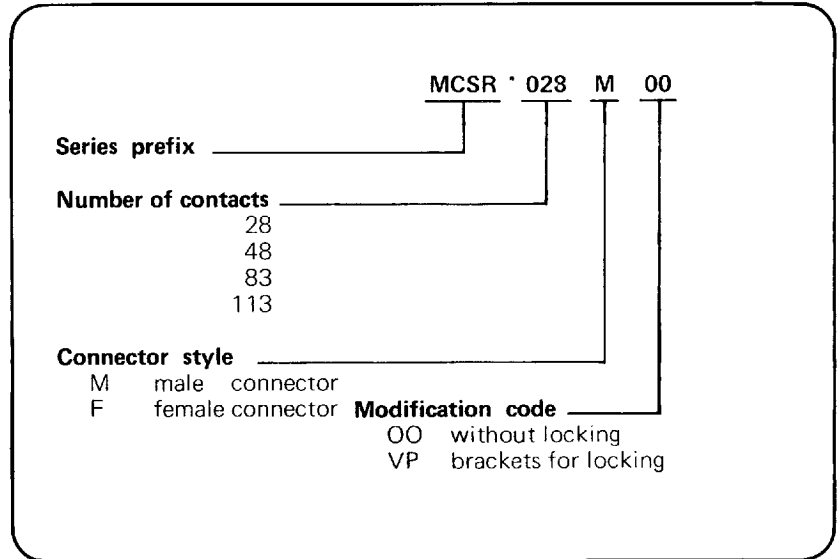

# TERMINATION STYLE

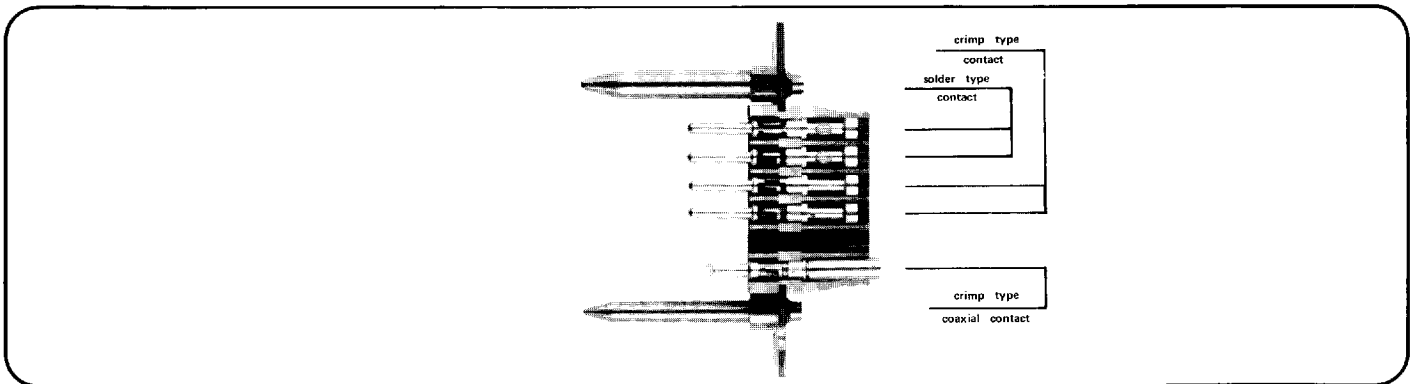

# CONTACT ARRANGEMENTS

28 contacts

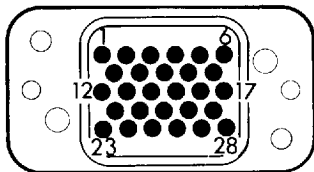

83 contacts

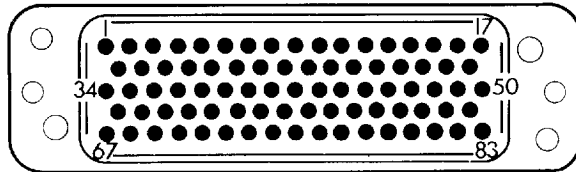

48 contacts

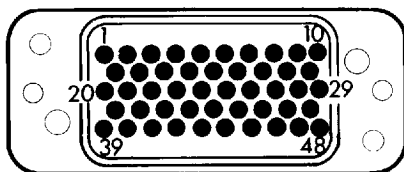

113 contacts

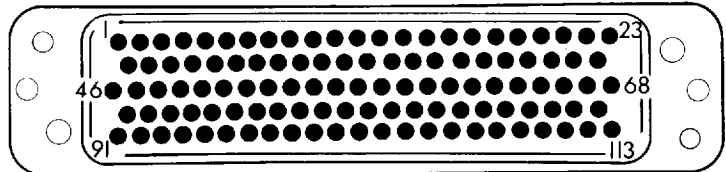



# DIMENSIONAL DATA

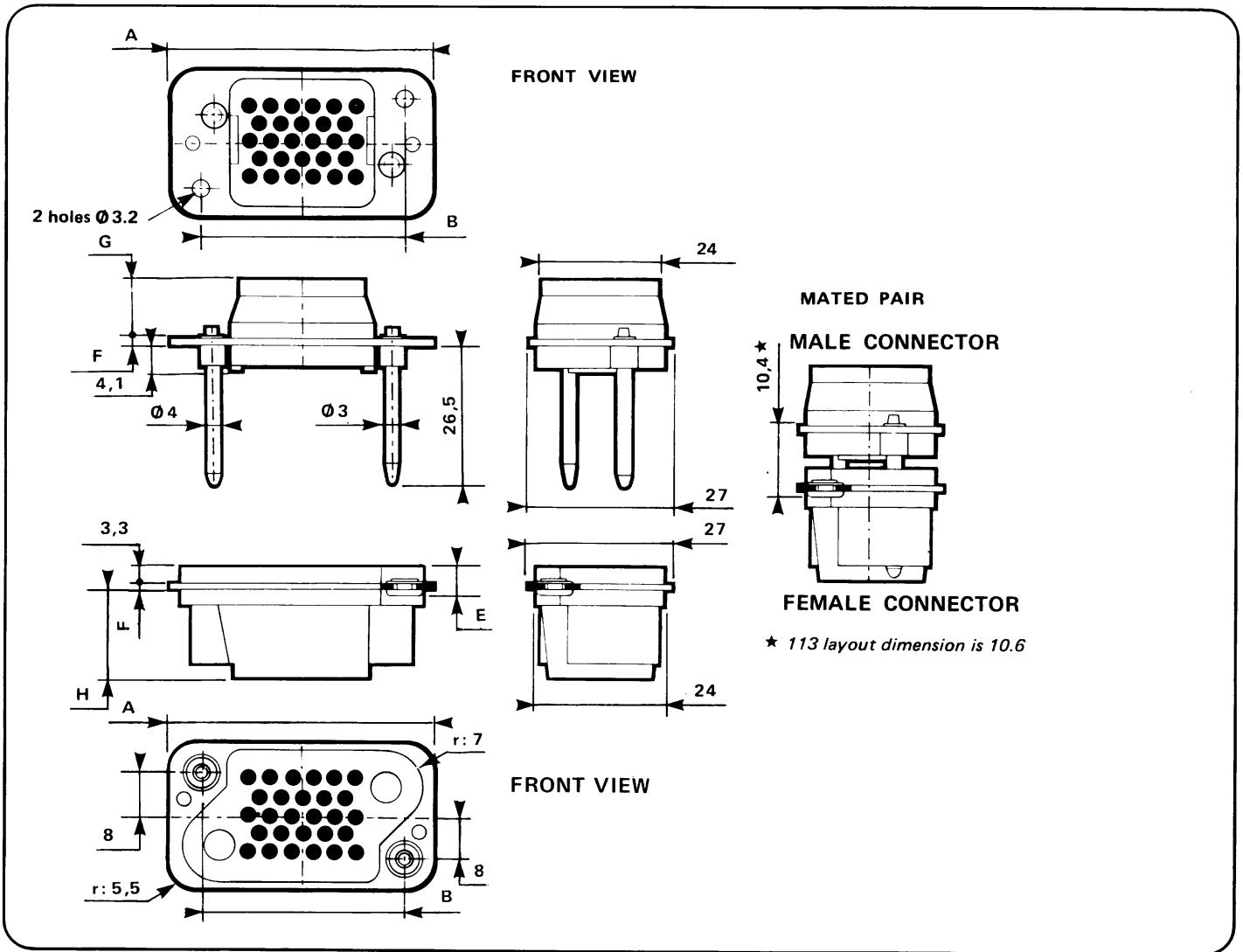





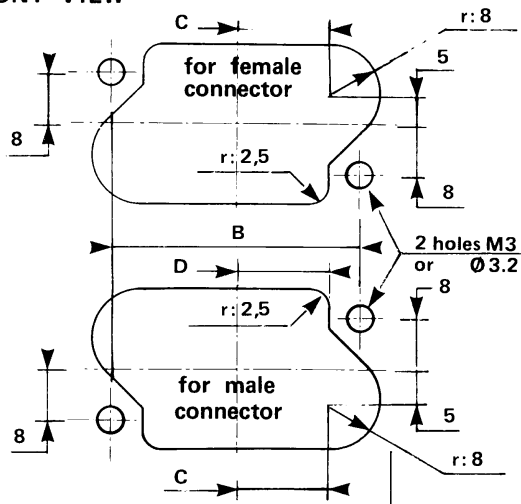











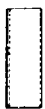











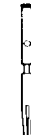

## PANEL CUT OUTS

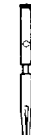
FRONT VIEW

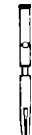

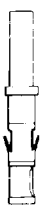
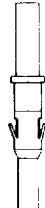
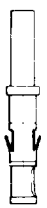
Number of contacts	Male and Female connector dimensions							
	A	B	C	D	E	F	G	H
028	48,5	37,5	15,75	15,5	5,3	1	11,5	17,7
048	65	54	24	23,5	5,3	1	11,5	17,7
083	92,5	81,5	37,75	37,5	5,3	1	11,5	17,7
113	114,5	103,5	48,75	48,5	5,5	1,2	11,3	17,5

# MICRO COAXIAL CONTACTS

Cables	Reference	RG. 178 B/U RG. 196 A/U KX. 21 A	RG. 174/U RG. 188 A/U RG. 316/U KX. 3A KX. 22 A	Twisted Pair cable	Twisted Pair cable				
	Dia. Sheath	2	2,6	1,1	1,3				
Impedance	50 Ω		50 Ω						
CONTACTS	Male	Female	Male	Female	Male	Female	Male	Female	
	690 020	614 120	690 040	614 140	690 060	614 160	690 070	614 170	
Ferrule 1									
Twisted pair adaptor 2									
Insulating bush 3									
Socket or pin contact 4									
Contact body 5									
Braid	Crimp tool	MS 22520/2 - 01 Sogie 282 281		MS 22520/2 - 01 Sogie 282 281		MS 22520/2-01 Sogie 282 281		MS 22520/2 - 01 Sogie 282 281	
	Setting	1		2		2		2	
Conductor	Crimp tool	M 22520/4 - 01 Sogie 282 292		M 22520/4 - 01 Sogie 282 292		M 22520/4 - 01 Sogie 282 292		M 22520/4 - 01 Sogie 282 292	
	Positioner	M 22520/4 - 02 282 973		M 22520/4 - 02 282 973		M 22520/4 - 02 282 973		M 22520/4 - 02 282 973	

# MICRO COAXIAL CONTACTS ASSEMBLY

## Micro coaxial assembly

Three different modes of assembly are to be considered following the cable type used.

The two first assemblies A and B are applicable for

braided coaxial cables, whilst the third assembly C is applicable for twin conductor cable. The three mounting procedures are identical for both contact types, pin and rocket.

## Mounting procedure

**A)** After sliding the ferrule over cable, and stripping the latter to the dimensions shown in A1.

- comb the braid in opening it up, strip the centre wire to the dimension shown in A2
- Slide the insulator bushing (3) over the dielectric
- Place the centre contact (4) over the conductor, the contact must butt against the insulator bushing (3)
- Crimp the centre contact with tool N° 282 281 page 12
- Slide the cable and contact into the body (5) ensuring that it's pushed home, then trim back the braid over the body (5)
- Slide the ferrule over the braid up to the body shoulder
- Place the assembly into tool N° 282 292 page 12
- Crimp the ferrule

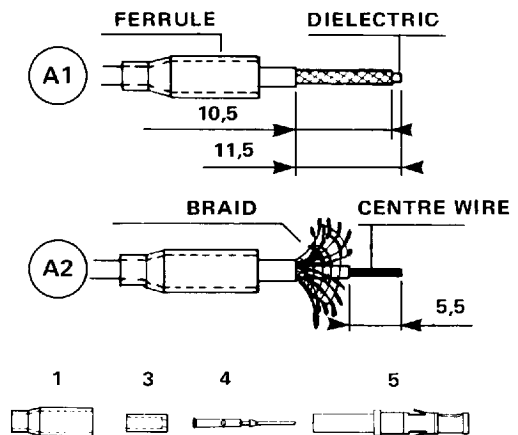

**B)** After sliding the ferrule over the cable, strip the latter to dimensions shown in B (mounting of coaxial contacts without insulator bushing)

- Comb the braid and place the centre contact over the conductor butting it against the dielectric
- Place the sub assembly into tool N° 282 281 page 12 and crimp the centre contact
- the following steps are identical to those indicated in A.

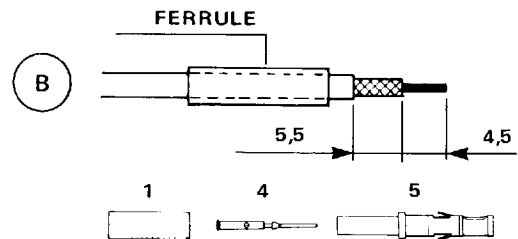

## Micro coaxial contacts with twin conductor cable

**C)** After sliding the ferrule over the twin conductors and stripping them to dimensions shown in C

- Note :** Conductor 1 is for the centre contact, whilst conductor 2 is for earthing.
- Slide the adaptor 2 and the insulator bushing (3) over conductor 1
  - Place the centre contact (4) over the conductor, butting it against the sheath
  - Place the sub assembly into tool N° 282 281 page 12 and crimp the centre contact
  - Slide the cable and contact into the body 5, ensuring that it's home
  - Slide the adaptor 2 onto the body 5 against the shoulder
  - Place conductor 2 into the helical slot
  - Slide the ferrule over the adaptor and conductor 2, up to the shoulder of the body 5
  - Place the assembly into tool N° 282 292 page 12 and crimp ferrule.

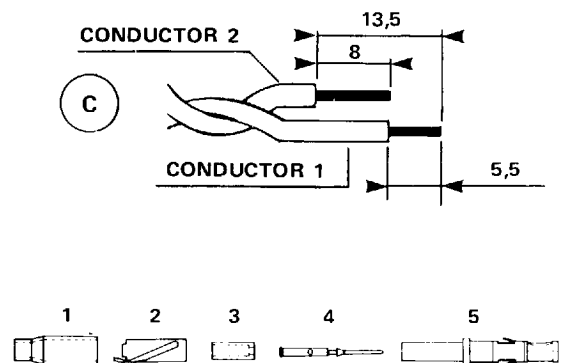

# TOOLS

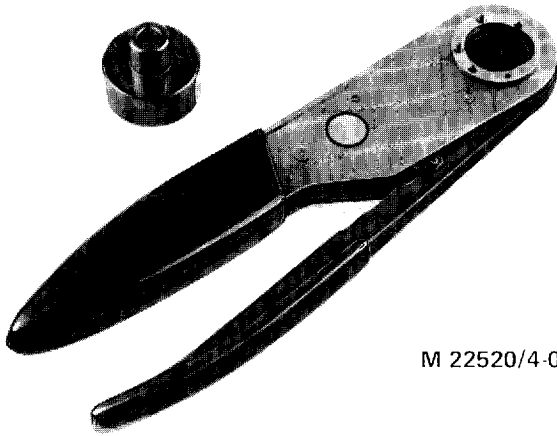

M 22520/4-01

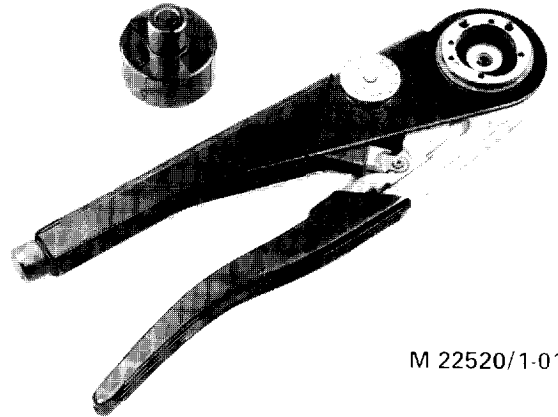

M 22520/1-01

## CONTACT TYPES

### CRIMP WIRE CONTACTS

Crimp tool **282 291** or M 22520/1.01  
 Positioner  
 – Gauge 16, 18, 20 **282 975**  
 – Gauge 20, 22, 24 **282 976**  
 Extraction tool **282 920**

AWG WIRE SIZE	PIN	SOCKET	CROSS Section mm <sup>2</sup>	Max. Insulator diameter	Stripping Length
16			1,34	3,10	6
18			0,93		
20	614 200	690 300	0,60		
20			0,60	2,20	5
22			0,38		
24	614 210	690 315	0,22		

### SOLDER WIRE CONTACTS

Extraction tool **282 920**

AWG WIRE SIZE	PIN	SOCKET	CROSS Section mm <sup>2</sup>	Max. Insulator diameter	Stripping Length
16			1,34	3,10	6
18			0,93		
20	614 230	614 330	0,60		
20			0,60	2,20	5
22			0,38		
24	614 240	614 340	0,22		

*Other termination . consult factory*

# LOCKING SYSTEM CODE VP

The brackets can only be used on the female connector and enables it to be fastened securely when its mating half is fitted with a hood. The brackets replace the floating eyelets on the female connector on both series B and MCSR when code VP is mentioned, and the corresponding hood must be ordered with the male connector.

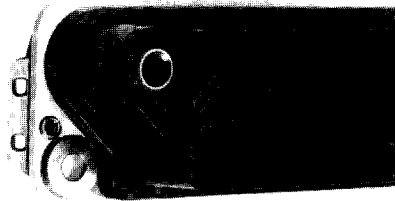

# CONNECTORS MOUNTING PLATES

The mounting plates already blanked out, simplify the wall cut out on the rack or panel as well as on any other item designed to support the connector. The latter is directly fitted to the mounting plate, which can then be easily secured with accuracy on the equipment due to the four oblong holes of the mounting plate.

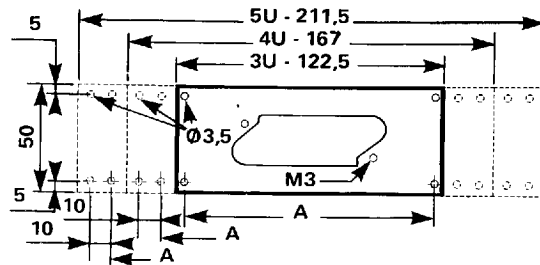
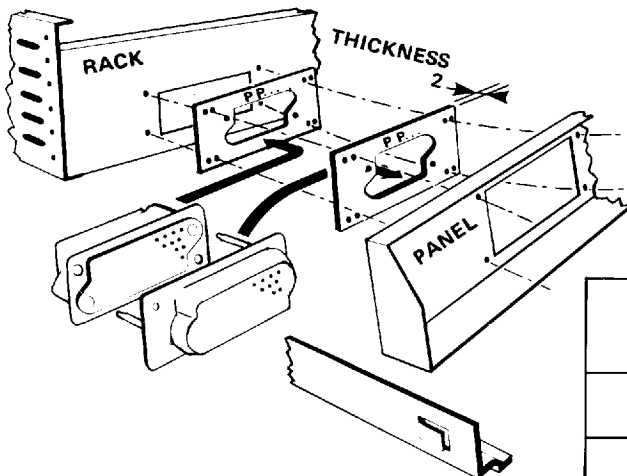

SÉRIES		Reference following number of cut outs		
B	MCS R	3 U	4 U	5 U
14	48	PP314	PP414	PP514
24	83	PP324	PP424	PP524
32	113		PP432	
Dimensions A		114,5	139	183,5

# HOODS TOP ENTRY

The hoods are available in four sizes, and are supplied in two halves which enables them to be fitted after the wiring of the connectors. They are available either with top or side cable entry (45°). Each hood is fitted with a pair of locking clips, one fixed on each end. This allows the connector hood assembly to be fastened securely to the mating connector fitted with the VP brackets.

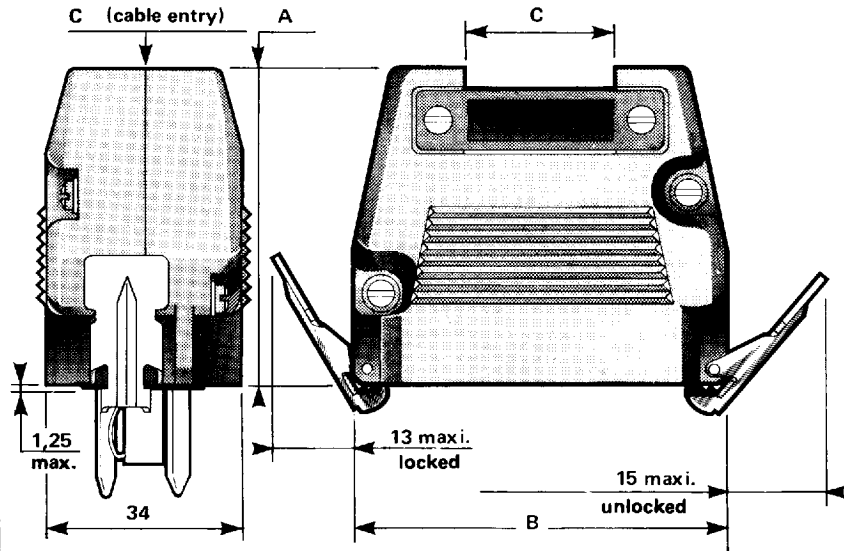
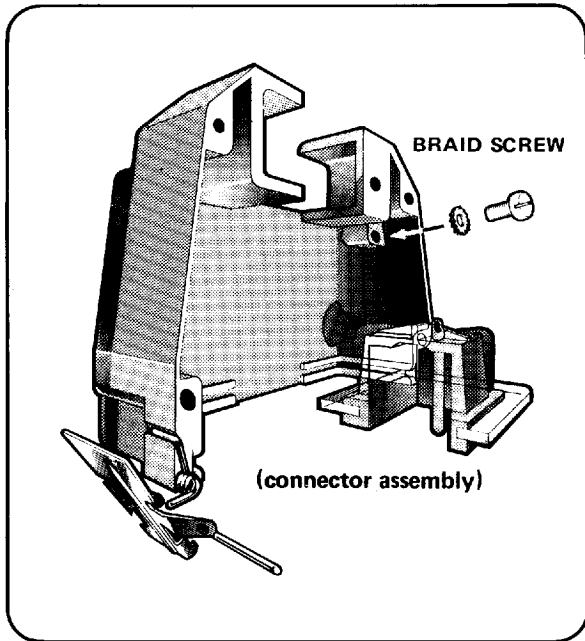

## HOOD REFERENCES

HOOD Top entry	Number of contacts		B and MCSR series Dimensions		
	B series	MCSR series	A	B	C
612 813	8	28	52,5	60,5	▧ 26 x 10
612 823	14	48	52,5	77	▧ 26 x 15
612 837	24	83	65,5	104,5	▧ 38 x 20
612 845	32	113	65,5	126,5	▧ 38 x 20

# HOODS CABLE 45° SIDE ENTRY

The hoods are available in four sizes and are supplied in two halves, which enables them to be fitted after the wiring of the connectors. Each hood is fitted with a pair of locking clips, one fixed on each end. This allows the connector hood assembly to be fastened securely to the mating connector fitted with the VP brackets.

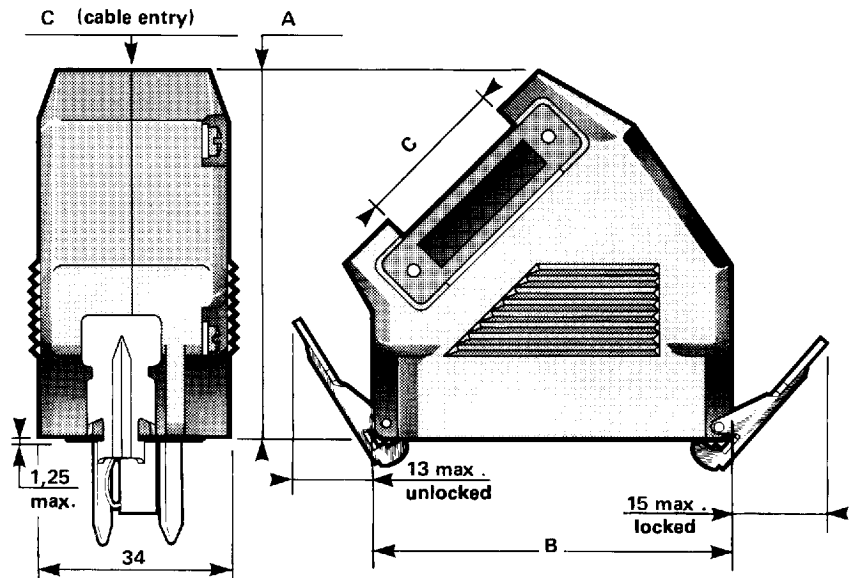
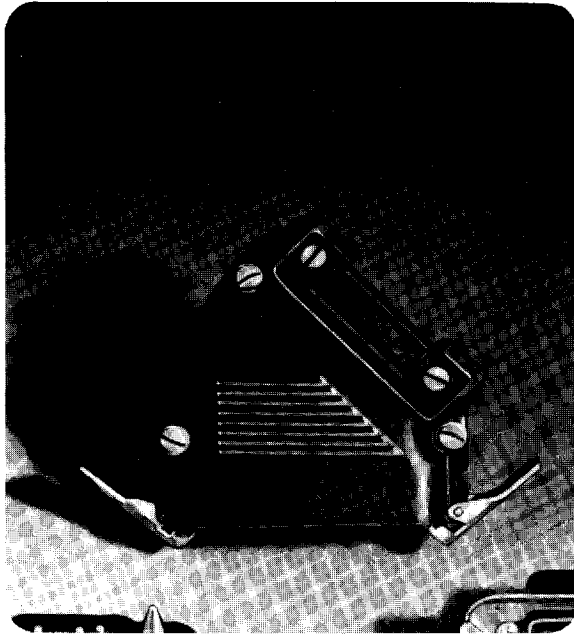

## HOOD REFERENCES

HOOD Top entry	Number of contacts		B and MCSR series Dimensions		
	B series	MCSR series	A	B	C
612 814	8	28	63	60,5	▧ 26 x 10
612 824	14	48	63	77	▧ 26 x 15
612 838	24	83	73	104,5	▧ 38 x 20
612 846	32	113	73	126,5	▧ 38 x 20